



# **DOPPIO CONTATTO**

## ***DOUBLE CONTACT***

Disponibile dal 16.11.15 / *avallale from 16.11.15*

# 4500

## MANDRINO PORTA PINZE ER ATTACCO DIN 69871 AD+B A DOPPIO CONTATTO

*Double contact collet chucks for ER Collets*

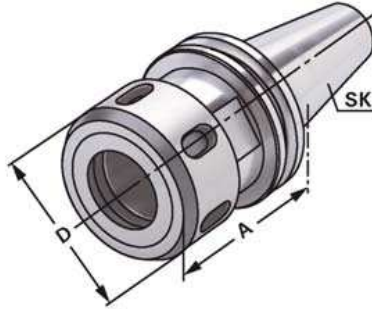

TIPO	A	D	d	Capacità Capability	Forma Form	Q	€
DCTC40ER16L70	70	31	28	1 – 10	ADB	2.5	
DCTC40ER25L70	70	42	36	1 – 16	ADB	2.5	
DCTC40ER32L70	70	50	44	2- 20	ADB	2.5	
DCTC40ER40L80	70	63	54	3- 30	ADB	2.5	

### Applicazione

Per il serraggio in pinza di  
utensili con attacco  
gambo cilindrico  
Precisione: 3 – 8  $\mu$   
bilanciati  
g 2.5 25.000 g/min.

### Application:

*For mounting straight-  
shank tools in collets.*  
*Run out: 3 – 8 $\mu$*   
*équilibrée*  
*g2.5 25.000rpm*

### Application:

*Pour le serrage d'outils  
avec queue  
cylindrique dans des  
pinces de serrage.*  
*Precision : 3 – 8 $\mu$*   
*balance*  
*g2.5 25.000rpm*

### Verwendung:

*Zur Aufnahme von  
Werkzeugen mit  
Zylinderschaft  
in Spannzangen.*  
*Präzision: 3 – 8  $\mu$*   
*gewuchtet g2.5*  
*25.000rpm*

### RICAMBI ED ACCESSORI

*Spare parts and accessories*

*Accessoires*

*Zubehör :*

ART. 2300,2320,2325,2360,2365, 2500, 2561, 2600

# 4570

## MANDRINI PORTA FRESE A SPIANARE ATTACCO DIN 69871 AD+B A DOPPIO CONTATTO

*Double contact shell end mill holders*

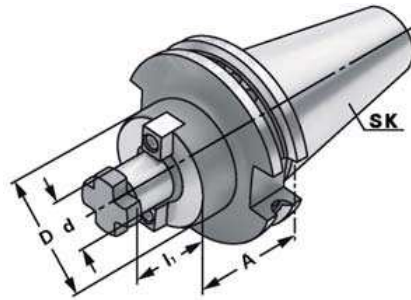

TIPO	A	l1	D	d	Forma Form	Q	€.
DCTC40D16F	46	17	38	16	ADB	2.5	
DCTC40D22F	51	19	48	22	ADB	2.5	
DCTC40D32F	51	21	58	27	ADB	2.5	
DCTC40D40F	60	24	66	32	ADB	2.5	

### **Applicazione:**

Per il montaggio di frese  
a spianare con  
trascinamento  
trasversale  
Bilanciato g2.5  
250.000giri/min

### **Application:**

*For mounting face end  
milling cutters with  
transversal  
groove.  
Balanced g2.5  
25.000rpm*

### **Application :**

*Pour le serrage de  
fraises à rainure  
transversale.  
Equilibrée g2.5  
25.000tpm*

### **Verwendung:**

*Zur Aufnahme von  
Messerköpfen und  
Fräsern  
mit Quernut.  
Gewuchtet g62.5  
25.000rpm*

### **RICAMBI ED ACCESSORI**

*Spare parts and accessories  
Accessoires  
Zubehör*

ART. 2580, 2592, 2640

# 4600

## MANDRINI PORTA FRESE TIPO WELDON ATTACCO DIN 69871 AD+B A DOPPIO CONTATTO

*Double contact mill holders weldon type*

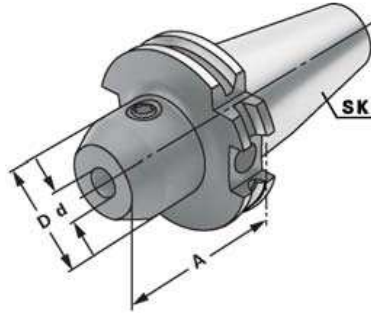

TIPO	A	d	D	Forma Form	Q	€
DCTC40WE 6	50	6	25	ADB	2.5	
DCTC40WE 8	50	8	28	ADB	2.5	
DCTC40WE10	50	10	35	ADB	2.5	
DCTC40WE12	50	12	42	ADB	2.5	
DCTC40WE16	35	16	45	ADB	2.5	
DCTC40WE20	35	20	45	ADB	2.5	
DCTC40WE25	35	25	45	ADB	2.5	

### **Applicazione:**

Per montare utensili con gambo cilindrico e attacco secondo norme din 1835 forma B (weldon)  
Bilanciato g2.5  
25.000giri/min

### **Application:**

*For mounting straight-shank tools with flat according to DIN 1835 form B (Weldon).  
Balanced g2.5  
25.000rpm*

### **Application:**

*Pour le serrage d'outils avec queue cylindrique et avec méplat suivant DIN 1835 forme B (Weldon)  
Equilibrée g2.5  
25.000tpm*

### **Verwendung:**

Zum Spannen von zylindrischen Werkzeugschäften mit seitlicher Spannfläche nach  
DIN 1835 Form B (Weldon)  
Gewuchtet g2.5  
25.000rpm

## **RICAMBI ED ACCESSORI**

*Spare parts and accessories*

*Accessoires*

*Zubehör :*

ART. 2597, 2598

# 4800

## MANDRINO PORTA PINZE ER ATTACCO MAS 403 BT AD+B A DOPPIO CONTATTO

*Double contact collet chucks for ER Collets*

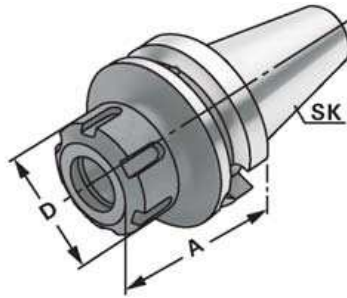

TIPO	A	D	d	Capacità Capability	Forma Form	Q	€
DCBT40ER16L70	70	31	28	1 – 10	ADB	2.5	
DCBT40ER25L70	70	42	36	1 – 16	ADB	2.5	
DCBT40ER32L70	70	50	44	2- 20	ADB	2.5	
DCBT40ER40L80	70	63	54	3- 30	ADB	2.5	

### Applicazione

Per il serraggio in pinza di utensili con attacco gambo cilindrico  
Precisione:  $3 - 8 \mu$   
bilanciati  
g 2.5 25.000 g/min.

### Application:

*For mounting straight-shank tools in collets.*  
*Run out:  $3 - 8 \mu$   
équilibrée  
g2.5 25.000rpm*

### Application:

*Pour le serrage d'outils avec queue cylindrique dans des pinces de serrage.*  
*Precision :  $3 - 8 \mu$   
balance  
g2.5 25.000rpm*

### Verwendung:

*Zur Aufnahme von Werkzeugen mit Zylinderschaft in Spannzangen.*  
*Präzision:  $3 - 8 \mu$   
gewuchtet g2.5  
25.000rpm*

### RICAMBI ED ACCESSORI

*Spare parts and accessories*

*Accessoires*

*Zubehör :*

ART. 2300,2320,2325,2360,2365, 2500, 2561, 2600

# 4870

## MANDRINI PORTA FRESE A SPIANARE ATTACCO MAS 403 BT AD+B A DOPPIO CONTATTO

*Double contact shell end mill holders*

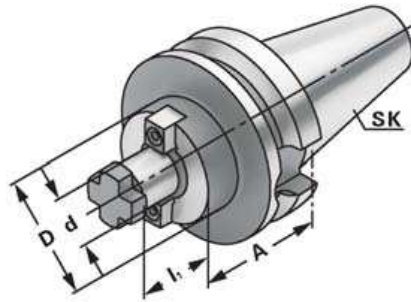

TIPO	A	l1	D	d	Forma Form	Q	€.
DCBT40D16F	45	17	38	16	ADB	2.5	
DCBT40D22F	45	19	48	22	ADB	2.5	
DCBT40D32F	52	21	58	27	ADB	2.5	
DCBT40D40F	52	24	66	32	ADB	2.5	

### **Applicazione:**

Per il montaggio di frese a spianare con trascinamento trasversale  
Bilanciato g2.5  
160.000giri/min

### **Application:**

*For mounting face end milling cutters with transversal groove.  
Balanced g2.5  
25.000rpm*

### **Application :**

*Pour le serrage de fraises à rainure transversale.  
Équilibrée g2.5  
25.000tpm*

### **Verwendung:**

*Zur Aufnahme von Messerköpfen und Fräsern mit Quernut.  
Gewuchtet g62.5  
25.000rpm*

## **RICAMBI ED ACCESSORI**

*Spare parts and accessories*

*Accessoires*

*Zubehör*

ART. 2580, 2592, 2640

# 4900

## MANDRINI PORTA FRESE TIPO WELDON ATTACCO MAS 403 BT AD+B A DOPPIO CONTATTO

*Double contact mill holders weldon type*

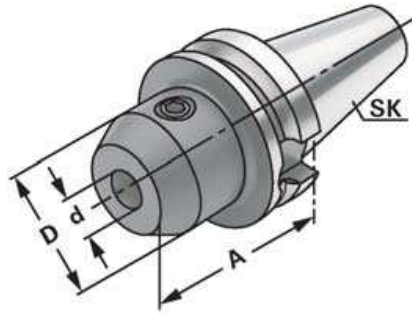

TIPO	A	d	D	Forma Form	Q	€
DCBT40WE 6	60	6	25	ADB	2.5	
DCBT40WE 8	60	8	28	ADB	2.5	
DCBT40WE10	65	10	35	ADB	2.5	
DCBT40WE12	65	12	42	ADB	2.5	
DCBT40WE16	35	16	45	ADB	2.5	
DCBT40WE20	35	20	45	ADB	2.5	
DCBT40WE25	35	25	45	ADB	2.5	

### Applicazione:

Per montare utensili con gambo cilindrico e attacco secondo norme din 1835 forma B (weldon)  
Bilanciato g2.5  
25.000giri/min

### Application:

*For mounting straight-shank tools with flat according to DIN 1835 form B (Weldon).  
Balanced g2.5  
25.000rpm*

### Application:

*Pour le serrage d'outils avec queue cylindrique et avec méplat suivant DIN 1835 forme B (Weldon)  
Equilibrée g2.5  
25.000tpm*

### Verwendung:

Zum Spannen von zylindrischen Werkzeugschäften mit seitlicher Spannfläche nach  
DIN 1835 Form B (Weldon)  
Gewuchtet g2.5  
25.000rpm

### RICAMBI ED ACCESSORI

*Spare parts and accessories*

*Accessoires*

*Zubehör :*

ART. 2597, 2598